

# HYPOTHESIS OF EXPLOSION IN THE LEFT WING OUTER FUEL TANK OF TU-154M DUE TO ELECTRICAL IGNITION OF FUEL-AIR MIXTURE

Jacek F. Gieras

## Abstract

The fuel system and possibility of explosion of fuel-air mixture as a result of arcing and/or static electricity in the left wing outer fuel tank of Tu-154M Nr 101 has been analyzed. Examples of explosions of fuel tanks (Boeing 747-131 TWA 800 on June 17, 1969 and Boeing 727-200 at Bangalore Airport on May 4 2006) have been discussed. Although probability of explosion of fuel in the left wing outer tank due the electric short circuit, arcing or static electricity is low, this problem should be carefully considered in future examination of the wreckage and remaining electrical wiring and equipment.

**Keywords** – Explosion, fuel-air mixture, fuel tank, electric equipment, Tu-154M, wiring .

## Streszczenie

Przedstawiono analize układu paliwowego oraz mozliwosci wybuchu mieszanek paliwo-powietrze na skutek luku elektrycznego lub ladunkow statycznych w samolocie Tu-154M Nr 101. Do wybuchow zbiornikow paliwa doszlo podczas lotu Boeinga 747-131 TWA 800 17 czerwca, 1969 oraz podczas postoju Boeinga 727-200 na lotnisku Bangalore 4 maja 2006). Chociaz prawdopodobienstwo wybuchu paliwa w zbiorniku zewnetrznym lewego skrzydla na skutek zwarcia instalacji, luku elektrycznego czy tez ladunkow statycznych jest niskie, problem ten powinien byc dokladnie rozwazony podczas przyszlych badan wraku oraz dostepnych urzadzen i przewodow elektrycznych.

**Słowa kluczowe** – mieszanek paliwo-powietrze, przewody elektryczne, wybuch, wyposazenie elektryczne, Tu-154M, zbiornik paliwa.

## 1. INTRODUCTION

On April 10, 2010 a Polish Air Force Tupolev Tu-154M, registration number 101 carrying Poland's president Prof. Lech Kaczynski, the First Lady Mrs Maria Kaczynska, top Polish Army generals, Polish representatives, and many distinguished Polish persons performing a states flight from Warsaw (Poland) to Smolensk (Russia) crashed onto the ground coming to rest about 500 m short of the runway threshold of Smolensk North (Severnny) Airport [XUBS]. All 88 passengers and 8 crew members have been killed. The debris field being about 210 meters long shows unbelievable fragmentation of the aircraft since the speed of the aircraft was only 270 km/h and the aircraft hit the boggy and woody ground. The crash investigation has been handed over by Polish authorities to Interstate Aviation Committee (Межгосударственный авиационный комитет - МАК). The wreckage and flight recorders (black boxes) have not been returned to Poland and are still kept in Russia.

According to official investigations [6,7], the cause of crash was collision with trees while landing in dense fog. At the distance of 855 m before the threshold of runway and 63-m left from its center line, the left wing of the aircraft hit a birch tree with the trunk diameter of 0.3 to 0.4 m and at the height of 5.1 m. As a result, the tip of the left wing of 6.1-m long between the 27<sup>th</sup> and 28<sup>th</sup> rib has been severed. The first ground impact was 525 m before the threshold of the runway and 105-m left from its center line. Distribution and shape of debris, dismembered bodies as well as lack of crater and fuel fire suggest rather explosion above the ground than ground impact [16].



Fig. 1. Plane crash site on April 12, 2012. Source: Global Digital.

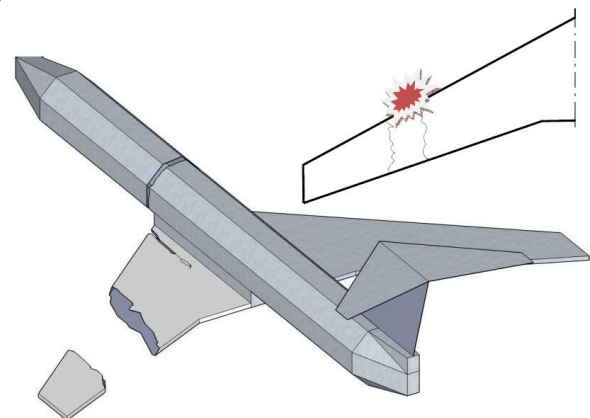

Fig. 2. Hypothesis of explosion in the left wing [16].

## 2. PROBLEM STATEMENT

According to [8], Section 4.10.3], the lost of the left portion of the wing has caused the burst of the left fuel tank Nr 3, which is placed between rib nr 14 and 45. The severance of the 6.1-m long tip of the left wing was between the ribs nr 27 and 28.

Professor Jacek F. Gieras, PhD, DSc, FIEEE, University of Technology and Life Sciences, Department of Electrical Engineering, Bydgoszcz, Poland (e-mail: jacek.gieras@utp.edu.pl).

Since the severance of the wing tip as a result of collision with 0.3 to 0.4-m diameter birch tree is rather impossible, the problem should be stated in opposite way: *The burst of the left fuel tank Nr 3 caused lost of the left portion of the wing.*

If the explosion on Tu154M was due to action of the third party, installation of explosive in the left wing was not necessary. Electric installation could be adequately prepared<sup>1</sup> to obtain a delayed short circuit, i.e., in electric wiring for electricity supply to electric motors of fuel pumps installed in the left wing tank Nr 3. It is necessary to mention that alterations to Salon No 3 were made on April 6, 2010.<sup>2</sup>

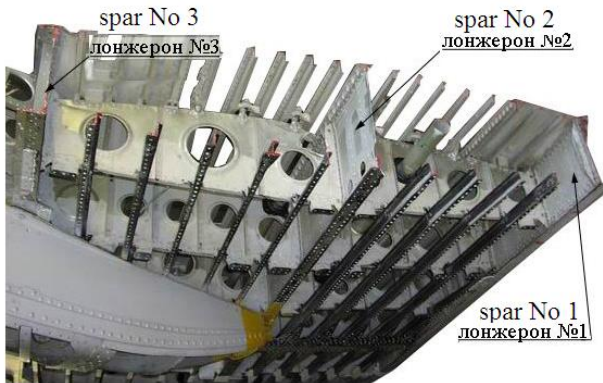

Fig. 3. Construction of Tu-154 wing [19].

Possible reasons for explosion in the left wing include, but are not limited to:

- Ignition of fuel-air mixture due to arcing in electric wiring or electric equipment;
- Explosive present in the left wing.

The construction of Tu-154 wing is shown in Fig. 3. Its main parts are 3 spars, the upper and lower panels and 45 ribs. Wing ribs are perpendicular to the axis of the third spar. The chambers in their center parts are sealed and used as fuel tanks [1,17,19].

### 3. EXAMPLES OF EXPLOSIONS OF FUEL TANKS

In older (and also many new) types of passenger aircraft electric wires belonging to different electric circuits are laid in common bundles [5,20]. It is economical solution, which reduces the cost of electrical wiring. On the other hand, ageing and deterioration of insulation, wire overheating, short circuit or electric arcing in one electric circuit can make damage to insulation and short circuit of wires belonging to other electric circuits. Thermal protections are sometimes not reliable. For example, short circuit in a bundle of electric wires caused ignition of fuel-air mixture in the center wing tank (CWT) of Boeing 747-131, flight TWA 800 on June 17, 1996 (Fig. 4). Burst of CWT led to destruction of the aircraft over the Atlantic Ocean [15].

Explosion in the left wing fuel tank also took place on May 4, 2006 in Boeing 727-200 belonging to Malaysian Transmile Airline at Bangalore Airport, India [18]. Boeing 727 is very similar to Tu-154M. Explosion destroyed the structural integrity of the left wing. Investigators have found damaged electrical installation and electrical arcing in

aluminum tube with 115-V AC cable feeding fuel pump motor in the left wing tank (Fig. 5).

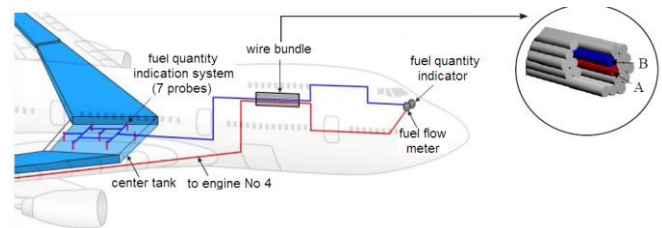
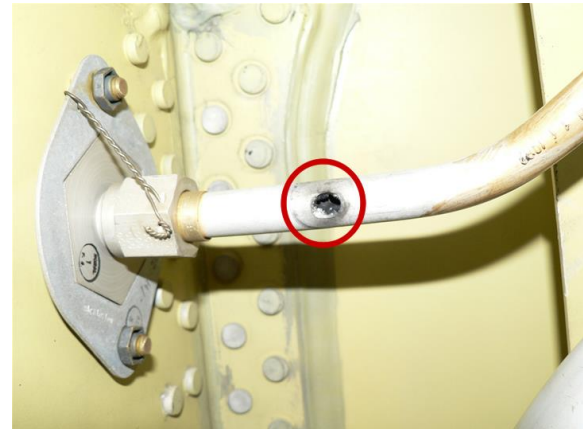

Fig. 4. Wiring configuration on the Boeing 747. Investigators suspect that high voltage from the fuel flow meter A passed to the fuel quantity indication system (FQIS) B because of a short circuit in the wire bundle [15].



Rys. 5. Evidence of electrical arcing of the wiring inside the exploded fuel tank of Boeing 727-200, Transmile Airlines, Bangalore, May 4, 2006 [18].

### 4. TU-154M FUEL SYSTEM

Civil transport aircraft use the wing structure as an integral fuel tank to store fuel. In larger aircraft, the fuel is also stored in the structural wing box within the fuselage. A typical wing tank is irregular, long and shallow [11]. The fuel is in direct contact with the outside skin. Tu-154M has six fuel tanks: one central fuel tank (CWT) Nr 1, two inner wing tanks Nr 2, two outer wing tanks Nr 3 and one additional tank Nr 4. The Tu-154M fuel tank configuration is shown in Figs 6 and 7. Tanks Nr 3 are between spars 1 and 3 and ribs 14 and 45 of detachable parts of wings [17].

The CWT tank is generally categorized as hazardous due to the proximity to external heat sources, e.g., airconditioning units [11]. It requires tank inerting with the aid of nitrogen-enriched air from the on-board inert gas generating system. The tanks Nr 1 and 4 of Tu-154M are inerted in the case of emergency landing without landing gears. The left and right wing tanks are usually categorized as nonhazardous as there is mostly no proximity of heat sources [11]. The wing leading edge slat section is equipped with anti-ice control system, typically with hot air ducts. These ducts take form of pipes with holes to allow air to heat the inner surface of leading edges. The hot air flow to the outer wing leading edges is controlled by the wing anti-ice valve [11]. Tu-154M has electric anti-ice control system with heating elements embedded in slats. Malfunction of electric anti-ice control system can theoretically cause dissipation of heat in the vicinity of the wing fuel tank Nr 3 (Section 6). According to [7] the electric anti-ice system of slots has not been activated during the flight Warsaw-Smolensk on April 10, 2010.

<sup>1</sup> This is a separate problem.

<sup>2</sup> Hangar No 21, in which alterations to Salon No 3 were made, has been recently demolished.

**Table 1. Fuel pumps of Tu154M.**

Specifications	ЭЦН-319	ЭЦН-323	ЭЦН-325
Type of pump	Emergency booster	Transfer	Booster
Electric motor	DC	Induction	Induction
Voltage, V	27	200	200
Rated current A	< 15	< 2.6	< 8.3
Starting current	unknown	< 15.6	49.8
Pressure drop, kG/cm <sup>2</sup>	1.6	0.45	1.25
Flow, l/h	1500	2000...700	3500...12,00
Mass of pump, kg	3.8	4.0	5.8
Number of pumps	2	12	4

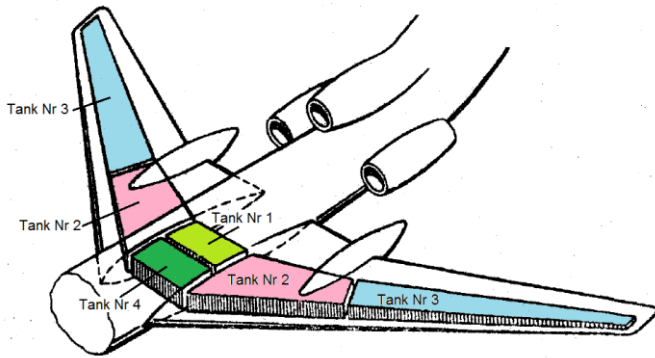

**Fig. 6. Tu-154M fuel tank configuration: Nr 1 – center wing tank (CWT), i.e., collector tank, Nr 2 – inner left and right wing tank, Nr 3 – outer left and right wing tank, Nr 4 – additional tank [17].**

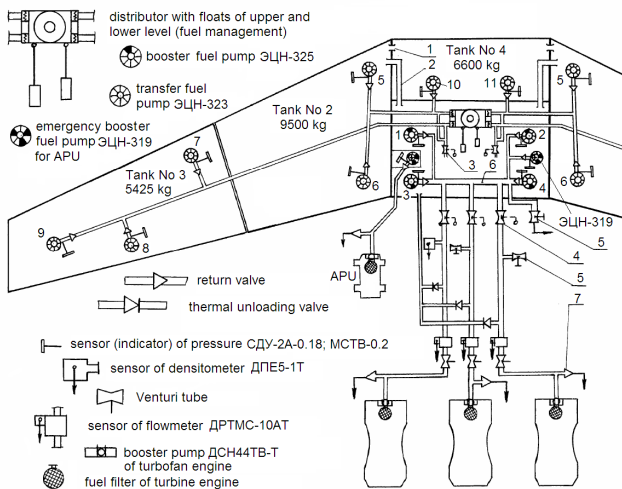

**Fig. 7. Tu154M fuel system layout. Fuel tanks, fuel pumps, fuel transfer lines, Д30KV engine and APU have been shown. 1,2 – feed lines of upper transfer from tanks 4 and 1 to tank 2; 3 – faucet of reserve transfer; 4 –antifire faucet; 5 – discharge faucet, 6 – connector for maintenance of engines [17,19].**

Fuel pumps of Tu-154M are driven by 115/220-V induction motors and DC 27 V brush motors (Table 1). Flange mounted motor and pump constitute one integral unit (Fig. 8a). The feeding cables in fuel tanks are in aluminum tubes (Fig. 8b). Arcing in wiring system that delivers electric energy to fuel pump motors can theoretically ignite the fuel-air mixture in the wing tank [2,9,11,12,13].

In general, there are two types of fuel pumps on typical aircraft [11]:

- Fuel *transfer pumps* (ЭЦН-323), which perform the task of transferring fuel between the aircraft fuel tanks to ensure that the engine fuel feed requirement is satisfied

- Fuel *booster pumps* (ЭЦН-325, ЭЦН-319), also called *engine feed pumps*, which are used to boost the fuel flow from the aircraft fuel system to the engine.

Commercial aircraft use *open vent system* to connect the ullage space above the fuel in each tank to the outside air [11]. Tu154M is equipped with the vent system.

Tu-154 uses fuel Jet A-1. Jet A-1 is a kerosene grade of fuel suitable for most aircraft turbine engines. It is produced to a stringent internationally agreed standard.

Fuel samples have not been collected by the Committee for Investigation of National Aviation Accidents (KBWL<sup>3</sup>) from the crash site for testing. KBWL tested fuel taken from the cistern UJ00204 at Warsaw Airport. Laboratory tests have confirmed that the fuel meets quality requirements (Raport Nr WK-2913-55-143-10). According to [6], fuel samples taken from the wreckage for tests by Russian Interstate Aviation Committee MAK has confirmed good quality of fuel.

According to [8], Section 4.10.3, the Tu-154M was fueled on April 7 (22 568 l) and April 9<sup>4</sup> (9518 l). The airplane was not refueled on April 10, 2010.

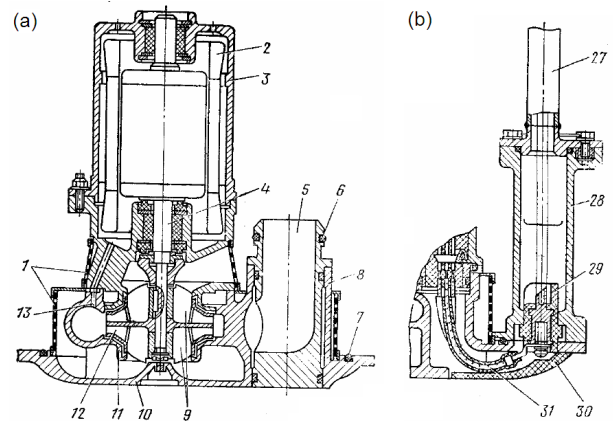

**Fig. 8. Booster fuel pump ЭЦН-325: (a) cross section of fuel pump and induction motor; (b) electric wires. 1 – grid, 2 – induction motor, 3 – motor housing, 4 – shaft, 5 – tube, 6,7 – sealing rubber rings, 8 – pump housing, 9 – rotor, 10 – cover, 11 – snail, 12 – impeller, 13 – channel, 27 – conduit metal tube, 28 – tubing, 29 – terminal block, 30 – cover, 31 – electric cable. Construction of transfer fuel pump ЭЦН-323 is similar [1,17].**

**Table 2. Capacity of fuel tanks before and after crash.**

Nr of tank	Nominal capacity, kg	Last refueling, kg	After crash, kg
Nr 1 CWT (collector tank)	3300	3300	3150 to 3300
Nr 2 (two tanks)	2 x 9500 = 19 000	4000	0
Nr 3 (two tanks)	2 x 5425 = 10 850	5372	1300 to 1450
Nr 4 (additional tank)	6600	6000	6000
Total	39 750	1 8 672	10 450 to 10 750

Assuming that fuel is equally distributed between the left and right wing tanks Nr 3, it should be from 650 to 725 kg fuel in the left wing tank Nr 3 at the time of crash [4], Section 4.10.3. The surface of the bottom of the tank Nr 3

<sup>3</sup> In Polish „Komisja Badan Wypadkow Lotniczych Lotnictwa Cywilnego” (KBWLLC or KBWL).

<sup>4</sup> After return of D.Tusk from Prague.



has been estimated approximately as 57 m<sup>2</sup>. Assuming the specific mass density of Jet A-1 fuel as 800 kg/m<sup>3</sup>, the fuel level in the tank Nr 3 was from 14 to 16 mm. Such a thin layer of fuel on the bottom of a tank needs minimal heat input to the tank walls to reach the temperature exceeding the flash point and form combustible vapors in the ullage<sup>5</sup>.

Annexure [4], Section 4.5, p. 28/28 says that during *visual inspection of wreckage, no trace of detonation of explosive and fuel has been found*. Visual inspection cannot detect explosives. Detailed chemical examination and analysis of the wreckage must be done.

## 5. TU-154M WING ANTI-ICE SYSTEM AND ELECTRIC WIRING

Most civil aircraft use hot bleed air for anti-ice control of outer wing leading edges [11]. Tu-154M must use electric resistive heating for anti-ice of the wing leading edge slats, as the turbofan engines are tail mounted and located far away from the wings. This would make the hot air bleed system very heavy and cumbersome.

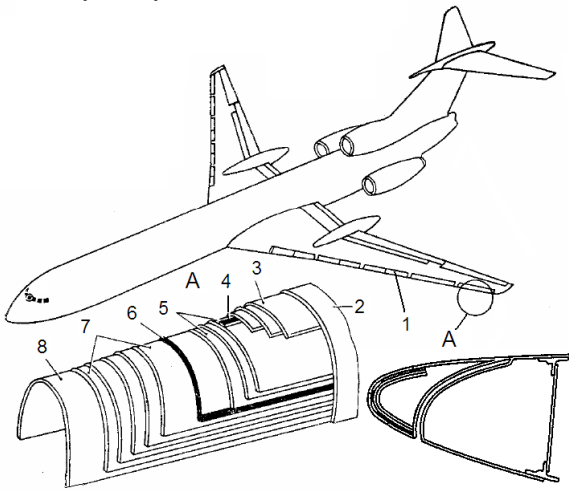

**Fig. 9.** Leading edge wing anti-ice system: 1 – slat, 2 – outer skin/sheathing, 3, 5, 7 – thermal glass insulation, 4 – thermal “knife”, 6 – heating element, 8 – inner skin/sheathing [1,19].

Tu-154M has three-phase, 115-V electrical wing anti-ice heating system (Fig. 9) [1,19]. To save electrical energy, heating elements are fed cyclically by adequate determination of time period. Under cyclic heating a thin layer of ice accumulates on slats which does not deteriorate aerodynamic properties of the aircraft. When the accumulation reaches a thickness threshold and the temperature of skin increases, the ice is taken out by the air stream.

The generator ГТ40ПЧ6 Nr 2 driven by the mid turbofan engine feeds only electric grid II dedicated to heating wing slats. The electric power is 43.6 kVA at 115 V and 130 A.

Heating elements (composites) of one half of slats are divided into eight sections. The other half of slats has also eight sections. Section are fed in the following sequence: 1<sup>st</sup>, 2<sup>nd</sup>, ... 8<sup>th</sup>, 1<sup>st</sup>, 2<sup>nd</sup>, ... 8<sup>th</sup> ... . Sections are numbered starting from the core part of the wing to the end of the wing. The current is on for 38.5 s and off for 269.5 s for each section.

In the leading part a thermal “knife” is installed along the slats. This part is made of 20-mm wide X20H80 NiCr foil.

The thermal knife is not fed cyclically – it is steadily under current and is isolated from the outer skin by three layers of glass fiber 3 (Fig. 9). Also, the three layers 5 isolate the thermal knife from the heating element. On the inner skin/sheathing of heating element of the slat, thermal switches for cyclic operation of sections and thermal “knife” are installed. Thermal switches protect slats and heating elements against overheating.

## 6. ELECTRIC IGNITION OF AIRCRAFT FUEL

Characteristics of aviation turbine engine fuel Jet A-1 are given in Table 3. Jet A-1 is a *kerosene grade* of fuel suitable for most turbine engine aircraft. This is a *complex mixture of hydrocarbons* consisting of paraffins, cycloparaffins, aromatic and olefinic hydrocarbons with carbon numbers predominantly in the C9 to C16 range [2].

The *flash point* of the fuel is the minimum temperature at which sufficient vapor is released by the fuel to form a flammable vapor-air mixture near the surface of the liquid or within the vessel used [2]. For Jet A-1 fuel the flash point is 38 °C (Table 3).

**Table 3.** Characteristics of fuel Jet A-1

Density at 15°C, kg/m <sup>3</sup>	775 to 840
Flash point, °C	38
Auto-ignition temperature, °C	210
Freezing point, °C	- 47 (- 40 for Jet A)
Open air burning temperature, °C	260 to 315
Maximum burning temperature, °C	980
Minimum net heat of combustion (specific energy), MJ/kg	42.8
Energy density, MJ/l	34.7

*Flamability limits* are experimentally determined upper and lower flammability boundaries of fuel concentration between which the fuel-air mixture only burns [3]. The upper (UFL) and lower (LFL) flammability limits in the air depend on initial temperature and pressure [3]. Thus, there is a limiting minimum and maximum *fuel-to-air* ratio. Below the LFL, the fuel-air mixture is too lean to burn. When UFL is exceeded, the vapor space mixture is too rich in fuel to be flammable. When considering only equilibrium conditions, the particular fuel-to-air ratio, which can exist is determined by the temperature and pressure of the system. The temperature determines the quantity of the fuel by controlling its vapor pressure, and the altitude determines the quantity of air. Therefore, by a suitable combination of temperature and altitude, under equilibrium conditions, the ullage of a fuel tank can be made either flammable or nonflammable [12].

As stated in Table 3, Jet A-1 fuel under static conditions is typically not flammable under 38°C. Small amount of fuel in the tank forms a very thin liquid layer across the bottom surface and is more dangerous than full fuel tank. Any heat input into this fuel layer can rapidly raise its temperature to above the flash point of the fuel, thus forming combustible vapors in the ullage. Table 4 lists sources and causes of fuel ignition (explosion) in the tanks.

There are many factors that determine how and how much this heat transfer affects the fuel tank temperature and the flammability of the ullage space. These factors include the operational environment, flight operations, condition of the aircraft, the amount and temperature of fuel loaded in the

<sup>5</sup> space between the fuel surface and upper wall of the tank.

tank, and other variables. In many cases, the fuel temperature is sufficiently high that the fuel-air mass ratio in the ullage space is above the lower flammability limit (fuel/air > 0.03).

**Table 4. Hazard and causes of fuel ignition in tanks.**

Hazard	Cause
In-tank electrical wiring	<ul style="list-style-type: none"> <li>• hot wires</li> <li>• short circuit</li> <li>• induced currents</li> <li>• chemical damage</li> <li>• mechanical damage</li> </ul>
Fuel pump motor wiring	<ul style="list-style-type: none"> <li>• short circuit</li> <li>• electric arcing</li> </ul>
Electric motor of fuel pump	<ul style="list-style-type: none"> <li>• interturn short circuit</li> <li>• phase-to-phase short circuit</li> <li>• phase-to-housing short circuit</li> <li>• hot spots</li> <li>• arcing on terminals</li> </ul>
Pump dry-running (there are fuel lubricated bearings)	Sparks generated due to mechanical friction
Adjacent systems, e.g., electric anti-ice system	<ul style="list-style-type: none"> <li>• electric arcing external to the fuel tank</li> <li>• heating of tank walls</li> <li>• explosion within the adjacent area</li> </ul>
Static electricity build-up due to fuel circulation [10]	Electrical discharge from fuel surface to tank walls
Lighting [4,9]	<ul style="list-style-type: none"> <li>• electrical discharges within the fuel tank</li> <li>• electrical arcing between components (inadequate distance between components)</li> </ul>

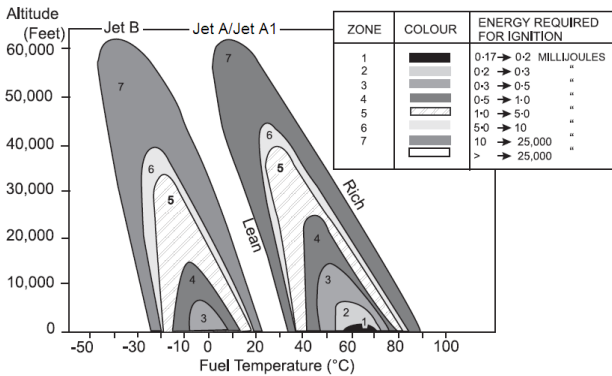
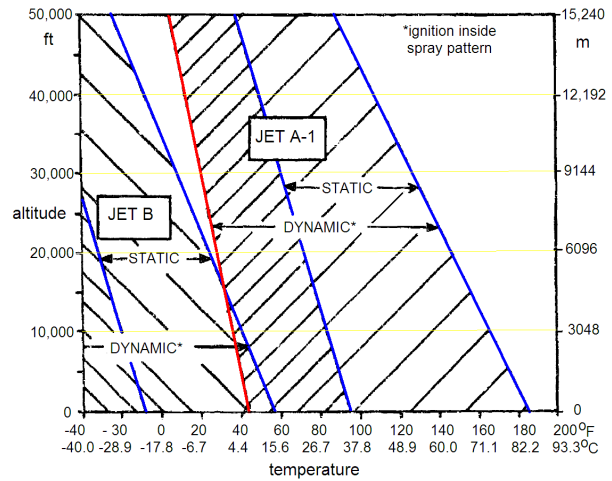

**Fig. 10. Flammability envelopes and estimated minimum electrical ignition energies for Jet A/Jet A-1 and Jet B fuels [2].**

The environmental parameters of temperature and altitude which will affect the flammability of the tank ullage, are illustrated by the so called *flammability envelope*. Traditional flammability envelopes have been available for many years [2]. The envelopes shown in Fig. 10 together with ignition energies, were derived by British Aerospace in the 1970's [2]. It should be noted that the flammability limits are not specification requirements, which include instead flash point, vapor pressure, and distillation of the particular fuel type.

Under dynamic conditions (pressure and temperature transient), the flammability envelope extends towards lower temperatures, as shown in Fig. 11 [12]. The dynamic flammability envelope for Jet A-1 fuel shows, that the flash point at low altitudes is as low as 4 to 5°C.

*Auto-ignition or ignition temperature* (Table 3) is the temperature at which the material will ignite on its own without any outside source of ignition.



**Fig. 11. Static and dynamic flammability envelopes for Jet A-1 and Jet B fuels [12].**

### 7. DESIGN OF FUEL TANKS

Since the introduction of kerosene fuel for civil aircraft use in the late 1940's, the aircraft designers have been aware that the ullage would contain a mixture of fuel vapor, or mist and air, which could be ignited in the presence of a spark, flame, or hot surface.

To prevent tank explosions, designers have always assumed a flammable vapor exists in the fuel tanks and adopted standards to preclude ignition sources from the fuel tanks. The following are some of the design measures taken to satisfy that philosophy [2]:

**A.** Surface temperatures inside the tanks, under normal and failure conditions, are kept at least 10°C below the minimum necessary to ignite a fuel-air mixture. Pump motors are kept cool by an integral passage of circulating fuel. The motors have a temperature fuse, which cuts the electrical supply before an unsafe surface temperature is reached. In addition, the pumps and other similar equipment inside the tanks, are designed and tested to explosion-proof standards. Bleed air pipes or electric heating elements in the wing leading edge are frequently routed close to fuel tank walls. In such a case, heat-sensitive detector wires are installed to protect fuel tanks from overheat.

**B.** Electrical components and wiring within a fuel tank are designed to handle 1500 V AC which is well in excess of the voltage available on the airplane.

**C.** Electrical energy applied to any component in the fuel tank is limited to a value that is 10 times lower than the minimum energy necessary to ignite a fuel-air mixture. The minimum ignition energy (MIE) for hydrocarbon vapors is about 0.25 mJ.

**D.** During the flow of a *hydrocarbon type fuel* through pipes, valves, filters, etc., an *electrostatic charge* can be generated in the fuel, which, if relaxed sufficiently fast, could allow the accumulation of hazardous potential levels inside a receiving tank. Therefore, it is necessary to avoid very high rates of fuel flow in the refueling system and control distribution of the fuel in the tanks (bottom loading and the use of diffusers on pipe outlets). In addition, meticulous attention is paid to electrical connection of all metallic parts to dissipate the charge. Some countries insist on the use of special additives in the fuels to increase the fuel electrical conductivity.

A major consideration of fuel system safety is protection against the affects of lightning [2,4,9]. When an aircraft is

struck by lightning, a pulse of high current flows through the aircraft from the entrance to the exit points. Protection against this phenomenon is provided in a number of ways (well bonded structure of aircraft, thick wing skin panels, proper location of tank vents, etc.).

## 8. WHAT COULD HAPPEN TO THE LEFT WING?

Only detailed investigation of wreckage can answer the question what really happened to the left wing of Tu-154M Nr 101. So far, the wreckage is not available to independent investigators and only photographs taken at the crash site can be examined.

Careful examination of crash site and description of debris could help to prove the hypothesis of fuel explosion. For example, a fuel pump (installed inside a fuel tank), if found on the debris field, would be a strong evidence of a fuel tank explosion.

The fuel tank Nr 3 was nearly empty, i.e., the thickness of the estimated fuel layer was from 14 to 16 mm spread over large surface of the tank (estimated surface of tank bottom about 57 m<sup>2</sup>). The partially empty fuel tank is more dangerous than the full tank as the ullage for the formation of flammable vapors is larger. The explosion in the left wing tank Nr 3 could be a result of

- (a) fuel ignition due to short circuit and arcing inside the tank Nr 3;
- (b) fuel ignition due to static electricity build-up;
- (c) explosion within the adjacent area of tank Nr 3.

Malfunction of anti-ice electric heating system installed in slats (Fig. 9) could lead to local temperature rise in the tank wall and create friendly conditions for fuel ignition by sparks or arcing. Fuel vapor auto-ignition due to local hot spot in fuel tank, or temperature rise due to malfunction of anti-ice electric system or other electrical equipment/wiring is rather impossible, since the auto-ignition temperature of Jet A-1 fuel is 210°C (Table 3). More realistic is electrostatic charge build-up due to fuel flow and hazardous electric potential level inside the tank.

Explosion within the adjacent area due to other than electrical causes should also be considered.

There is also enigmatic statement in [8], Section 4.10.3, p. 3/5: *At 05:59:005 UTC the flight recorders received a signal of failure or hand disconnection of control and measurement of fuel consumption system CYIT4-1T....The flight technician should immediately report all deviations in the fuel system to the aircraft commander. The cockpit voice recorder (CVR) does not show an evidence of such a report. It can be presumed that reconnection of control and measurement of fuel consumption system into manual mode was intentional.... However, the real cause of the reconnection of the control and measurement of fuel consumption system into manual steering mode remains unknown in this flight.*

## 9. CONCLUSIONS

Although probability of explosion of fuel in the left wing tank No 3 due the electric short circuit, arcing or static electricity is low, this problem cannot be neglected in further investigation of the accident, especially examination of wreckage and its remaining electrical equipment and left wing fuel tank No 3. Careful attention should be given to fuel pumps, induction motors for fuel tanks, slat electric

anti-ice system, all power cables/wires in fuel tank No 3 and in its vicinity.

The hypothesis of the second explosion in fuselage [16] could theoretically also be caused by explosion of fuel in CWT.

## Disclaimer

Although all precautions have been taken and all findings are documented by appropriate references, the analyzed scenario and cause of crash, unless confirmed by detailed investigation of the wreckage, is only a hypothesis.

## References

- [1] Aircraft Tu-154M, book 2, ed. V.M. Soshin, Samara State Aerospace University, Samara 2005.
- [2] A review of flammability hazard of Jet A fuel vapor in civil transport aircraft fuel tanks, ed. R. Hill, W.J. Hughes, Report DOT/FAA/AR-98/26, US Dept of Transp., Springfield, VA, 1998.
- [3] D. Bjerketvedt, J.R. Bakke, K. van Wingerden, "Gas explosion handbook", electronic book, <http://www.gexcon.com/handbook/GEXHBcontents.htm>
- [4] D.W. Clifford, "Aircraft mishap experience from atmospheric electricity hazards", AGARD Lecture Series No 110, 1980.
- [5] G. Ellis, "Air crash investigation of general aviation aircraft", Capstan Publications, Greybull, WY, USA, 1984.
- [6] Final Report on the investigation of air accident of Tu154M registration number 101 of the Republic of Poland, Interstate Aviation Committee (MAK), Moscow, 2011, [www.mak.ru/english/english.html](http://www.mak.ru/english/english.html)
- [7] Final Report on the examination of the aviation accident no 192/2010/11 involving the Tu-154M airplane, tail number 101, which occurred on April 10th, 2010 in the area of the Smolensk North airfield, Committee for Investigation of National Aviation Accidents, in Polish, Warsaw, 2011.
- [8] Flight technology and its utilization. Annexure Nr 4 to Final Report [7], Warsaw, 2011.
- [9] T.C. Kosvic, L.B., Zung, M. Gersten, "Analysis of fuel tank fire and explosion hazards", Technical Report AFAPL-TR-71-7, Air Force Propulsion Laboratory, WPAFB, Ohio, 1971.
- [10] J.T. Leonard, Generation of electrostatic charge in fuel handling systems: a literature survey, NRL Report Nr 8484, Naval Research Laboratory, Washington DC, 1981.
- [11] I. Moir, A. Seabridge, "Aircraft systems: mechanical, electrical and avionics subsystems integration", 3<sup>rd</sup> ed., J. Wiley & Sons, Chichester, England, 2008.
- [12] L.J. Nestor, "Investigation of turbine fuel flammability within aircraft fuel tanks", Naval Air Propulsion Center, Philadelphia, PA, Raport No DS-67-7, 1967.
- [13] J.E. Shepard, J.C. Krok, J.J. Lee, "Jet A explosion experiments: laboratory testing", California Institute of Technology, Pasadena, CA, 1977.
- [14] G. Slensky, "Aircraft wiring system integrity initiatives", AFRL, WPAFB, OH, <http://wire.nasa.gov>
- [15] System failure case studies in the sky, ed. Lilley, S, NASA, Safety Center, January 2011, <http://pmba.nasa.gov>
- [16] Szuladzinski, G., Some technical and constructional aspect of Smolensk's crash, in Polish, Raport No 456, Analytical Service Pty Ltd, Northbridge, Australia.
- [17] Tu-154M. User's technical guidance, Chpt. 28. Fuel system.
- [18] Update on investigation of airliner tank explosion in India, NTSB, July 12, 2006, <http://www.nts.gov/news/2006/060712a.htm>
- [19] Wing of Tu-154 aircraft, in Russian, Virtual cabinet of aircraft construction, [http://cnit.ssau.ru/virt\\_lab/kriolo/index.htm](http://cnit.ssau.ru/virt_lab/kriolo/index.htm)
- [20] R.H. Wood, R.W. Sweginnis, "Aircraft accident investigation", 2nd ed., Endeavor Books, Casper, WY, USA, 2006.